

Model #:
1000175-XX

1

On the list of device serial numbers, document the location for each sensor.

2

HBS is a wireless occupancy sensor, which provides world class motion detection in highbay areas to control Lighting applications.

- ❑ Turn power **OFF** at the circuit breaker before installing the sensor.
- ❑ Sensor must be installed and used in accordance with appropriate electrical codes and regulations.
- ❑ Installation to be performed by qualified and trained electrician.

3

INSTALLATION

The HBS-DC autaniNet wireless communication module is typically factory installed. If installation is required, then the HBS-DC module simply snaps into place as shown.

Note: A small screw driver is needed to open the HBS 300 to access the location of the HBS-DC.

4A

MOUNTING

PLACEMENT GUIDELINES - HBS 300

- ❑ Sensor module mounts to a 1/2" knockout of a lighting fixture or junction box.
- ❑ Detection lens must have a clear, unobstructed view of controlled area and must project beyond the lamps.
- ❑ Sensor should be 6 to 8 feet away from heating/cooling supply ducts.
- ❑ Ideal mounting height is up to 45 feet.
- ❑ Must be mounted on a stable platform.

END OF FIXTURE MOUNTING - HBS 300

The HBS 300 typically mounts to a 1/2" knockout at the end of a high/low bay lighting fixture. The sensor's lens should be mounted below the bottom edge of the fixture.

4B

EM 1 EXTENDER MODULE

The EM 1 Extender Module is recommended for use with the HBS 300 if the knockout at the end of the fixture is located greater than 1/2" from the bottom edge of the fixture.

JUNCTION BOX MOUNTING - HBS 300

If mounting to the end of a fixture is not possible, the HBS 300 can be mounted to any junction box with a 1/2" (trade size) knockout. With the HBS 300, this may be necessary if the fixture location has an obstruction that would block the view of the sensor (for example: racking is directly beneath the fixture).

5

WIRING - HBS 300

When installing the HBS-DC, ensure that power has been turned OFF at the breaker panel.

The leads consist of three wires:	When the HBS-DC is installed:
Black = line	Violet = DIM +
White = neutral	Pink = DIM -
Red = load	

Note 1: Dimming wires are only available with HBS-DC installed.

Note 2: All HBS and HBS-DC wires are Class 1 rated.

NOTE: Per NEC/UL, the 0-10V negative dimming wire color has changed from Gray to Pink effective January 1, 2022.

CONTINUED.....

6

OPERATION – WITH HBS-DC INSTALLED

OPERATION - HBS 300

The HBS 300 operates by turning lights on and dimming lights in response to scheduled or manual overrides initiated from the Autani Energy CORE/Manager.

Multiple HBS 300 units may be grouped together in the CORE/Manager so that occupancy transitions are shared by the group, turning lights ON and OFF in unison.

LIGHT LEVEL FUNCTION - HBS 300

The HBS sensor's light level feature will dim the fixture automatically if enabled in the Autani Energy CORE/Manager.

The light harvesting feature allows each light to maintain a constant level of illumination directly under the fixture. These settings must be configured in the Autani Energy CORE/Manager if the HBS-DC radio is installed.

INITIAL POWER UP - HBS 300

Upon initial power up, the load will turn ON for up to 18 minutes. If no motion is detected, the load will switch OFF. Once the HBS-DC has been configured by the Autani CORE/Manager, it will use its last stored motion delay value on subsequent power cycles until it regains communications with the CORE/Manager.

SURGE PROTECTION - HBS 300

The HBS sensor contains built in surge protection. This feature will reset the unit automatically after: power surges, power outages, and power shortages. Surge protection protects the sensor if it is miswired as well. If miswired, shut off power, correct the wiring, and the sensor will then operate correctly.

7A

SETUP & COMMISSIONING

HBS 300 COVERAGE

The HBS 300 contains three pyroelectric sensors to detect occupancy. At an installation height of 8 to 45 feet, maximum reach is 22 feet radial and 60 feet tangential. If needed, the detection zone can be adjusted (see next section).

7B

Coverage may vary depending on mounting height and environmental conditions.

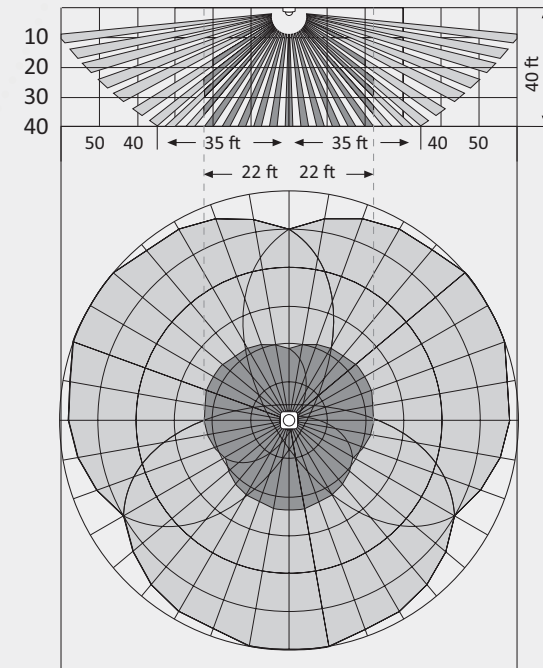

LENS COVERS

Lens covers can be used to adjust the HBS 300's coverage as needed. The covers are plastic and snap to the front of an HBS 300 sensor.

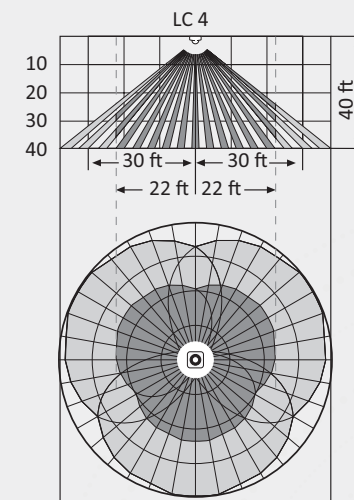
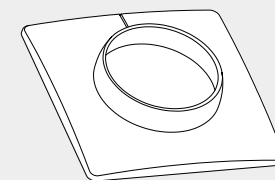

LC4 Reduced Range Lens Cover For HBS 300

7c

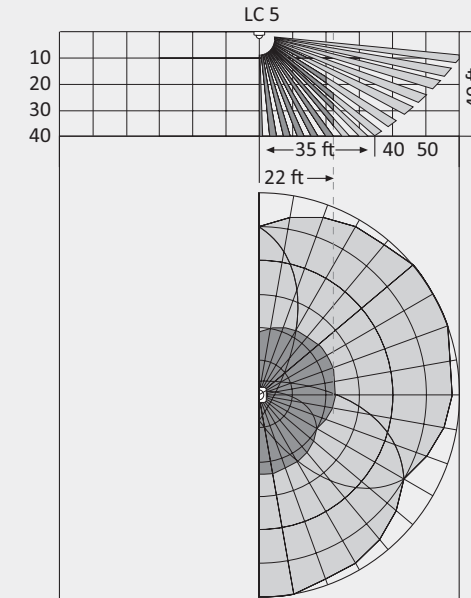
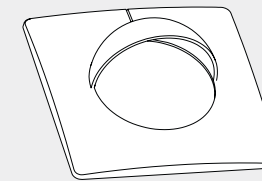

LC5 180° Half Moon Lens Cover for HBS 300

NOTE: The Light Level Setting (Low-High) and the DIP Switch Settings are ignored when the Autani HBS-DC Wireless Controller is installed. See product manual for setup information if using the HBS Sensor without the HBS-DC installed.

FACTORY RESET INSTRUCTION

Hold the magnet on the side of the unit centered on our SN label.

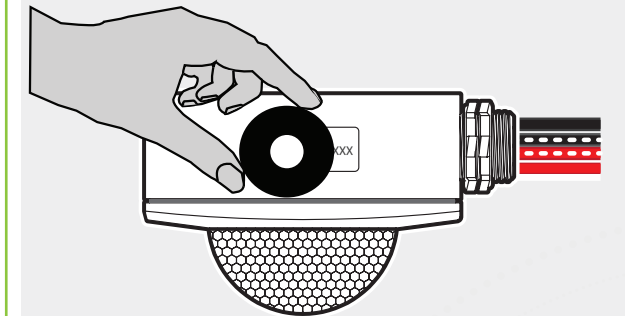

Once the Factory Reset is performed successfully, the device will search for a network and can be added through EnergyCenter®.